

# MERITOR® WHEEL SEALS

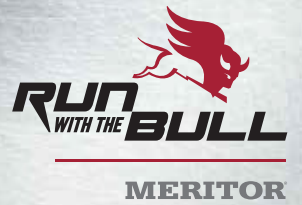

EASY-FIT & TOUGH DESIGN FOR  
SUPERIOR PROTECTION & OPTIMUM  
PERFORMANCE.



## ADVANTAGES

- 1 Four outside diameter seal points to ensure secure fit in the hub
- 2 Unique multi-zone labyrinth design provides the best protection and the lowest friction
- 3 Stiffer profile and thicker steel to withstand fitting forces
- 4 Rubber front face protects from brake heat
- 5 Unique low friction bumper significantly reduces run-in period, reduces required torque and keeps the seal cool from the outset
- 6 Large crumple zone/safety gap prevents internal damage
- 7 Wide inside diameter with three rubber-ribbed points to ensure proper sealing capability

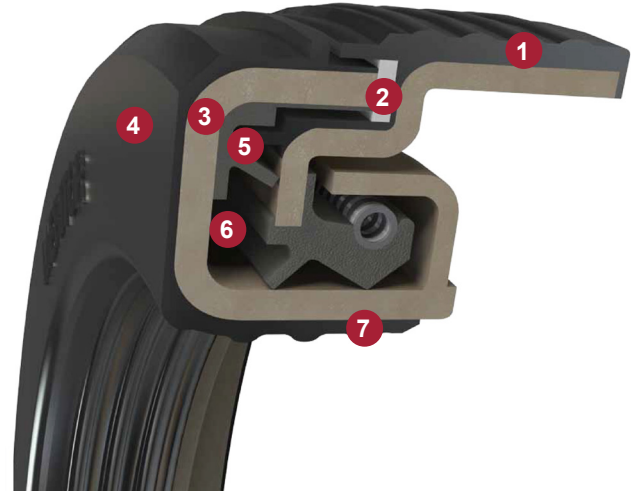

## FEATURES AND BENEFITS

- Standard wheel seals feature a nitrile compound rubber (NBR) for the sealing lip
- Premium wheel seals feature a hydrogenated nitrile butadiene rubber (HNBR), offering additional advantages of higher temperature capability, greater wear resistance and compatibility with all known synthetic lubricants
- The multi-zone labyrinth design and low-friction barrier deliver unmatched durability and protection against dirt, grime, water and other contaminants
- The bumper transmits the fitting force from the front of the seal to the outer diameter, and acts as the first defence against contaminants
- The seal provides outstanding lubricant retention and protection against contaminants, but they are also easier to install, which significantly decreases the potential for damage during installation

## STANDARD SEAL RANGE

MERITOR PART NUMBER	INDUSTRY CODE	E-BARRIER	SKF CLASSIC	NATIONAL 37	STEMCO VOYAGER	APPLICATION	GRADE
MER0113	40136	708	40136	370036A	373-0113	TRAILER - STANDARD FORGE, DANA	STANDARD
MER0123	42623	701	42623	370065A	373-0123	TRAILER - FRUEHAUF PROPAR	STANDARD
MER0136	35066	704	35066	370048A	383-0136	STEER - MERITOR, EATON	STANDARD
MER0143	46305	702	46305	370025A	373-0143	TRAILER - MERITOR GENERAL PURPOSE	STANDARD
MER0164	43764	705	43764	370048A	383-0164	STEER - MERITOR FL941 - MFS	STANDARD
MER0173	47697	709	47697	370003A	393-0173	DRIVE - MERITOR, DANA	STANDARD

## HIGH PERFORMANCE RANGE

MERITOR PART NUMBER	INDUSTRY CODE	E-BARRIER	SKF PLUS XL	NATIONAL 5 STAR	STEMCO DISCOVER	APPLICATION	GRADE
MER0213	40129	808	40129	380036A	373-0213	TRAILER - STANDARD FORGE, DANA	PREMIUM
MER0223	42627	801	42627	380065A	373-0223	TRAILER - FRUEHAUF PROPAR	PREMIUM
MER0236	35058	804	35058	380001A	383-0236	STEER - MERITOR, EATON	PREMIUM
MER0243	46300	802	46300	380025A	373-0243	TRAILER - MERITOR GENERAL PURPOSE	PREMIUM
MER0264	43761	805	43761	380048A	383-0264	STEER - MERITOR FL941 - MFS	PREMIUM
MER0273	47692	809	47693	380003A	393-0273	DRIVE - MERITOR, DANA, K-HITCH UNITISED AXLE	PREMIUM



**Meritor Heavy Vehicle Systems**  
 50 Calarco Drive  
 DERRIMUT VIC 3030  
 AUSTRALIA

Phone: (+61 3) 8353 6050  
 Fax: (+61 3) 8353 6060  
 Email: [cvaau.sales@meritor.com](mailto:cvaau.sales@meritor.com)

[meritorpartsexpress.com](http://meritorpartsexpress.com)  
[meritor.com](http://meritor.com)